

SM-27S/T FUEL QUANTITIES & TANK ARRANGEMENT

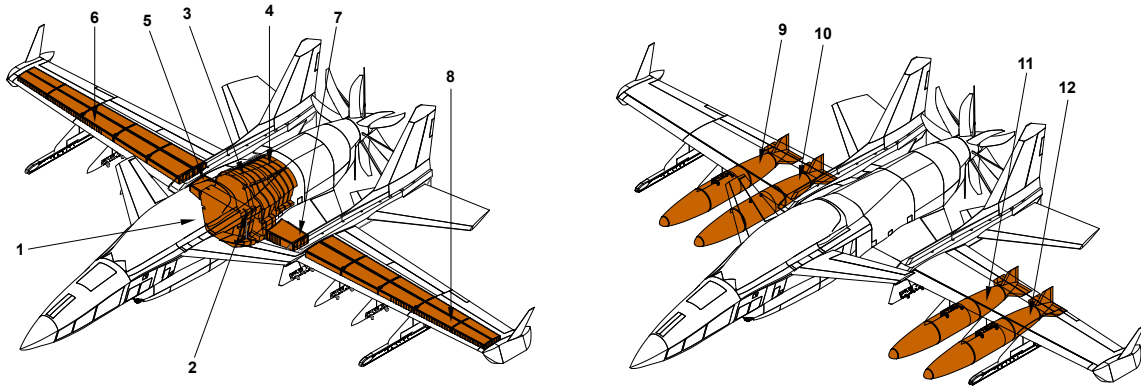

INTERNAL FUEL TANKS		USABLE FUEL			
TANK #	TANK LOCATION	US GALLONS	JP-4 POUNDS	JP-5 POUNDS	JP-8 POUNDS
1	Fuselage: 271101-T	104	673	705	694
2	Fuselage: 271201-T	56	366	383	377
3	Fuselage: 271301-T	215	1,400	1,465	1,443
4	Fuselage: 271401-T	160	1,043	1,091	1,075
5	Wing: 6902-R	15	97	101	100
6	Wing: 6906 & 6908-R	102	662	693	683
7	Wing: 6902-L	15	97	101	100
8	Wing: 6906 & 6908-L	102	662	693	683
TOTAL INTERNAL FUEL		769	5,000	5,231	5,154

EXPENDABLE/EXTERNAL TANKS		USABLE FUEL			
TANK #	TANK LOCATION	US GALLONS	JP-4 POUNDS	JP-5 POUNDS	JP-8 POUNDS
9	Right External: 401315	150	975	1,020	1,005
10	Right External: 401315	150	975	1,020	1,005
11	Left External: 401315	150	975	1,020	1,005
12	Left External: 401315	150	975	1,020	1,005
TOTAL EXPENDABLE/EXTERNAL		600	3,900	4,080	4,020

MAXIMUM AIRCRAFT FUEL: ALL TANKS	1,369	8,900	9,311	9,174
-----------------------------------------	--------------	--------------	--------------	--------------

NOTES:
 1) Fuel weights are based on JP-4 at 6.5 lbs/gal, JP-5 at 6.8 lbs/gal and JP-8 at 6.7 lbs/gal and an atmospheric temperature of 59°F.
 2) Fuel quantities, in pounds, are rounded to the nearest pound. The actual gallons times 6.5, 6.7 or 6.8 will not necessarily agree with the pounds column.