

## SM-47 T-X FUEL QUANTITIES & TANK ARRANGEMENT

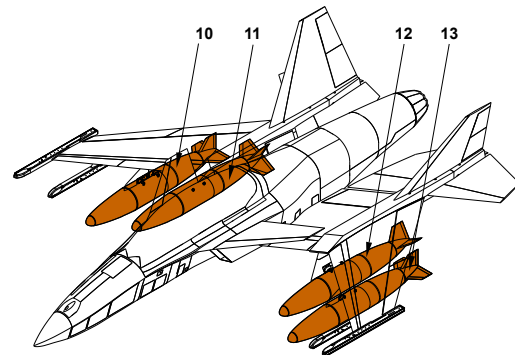
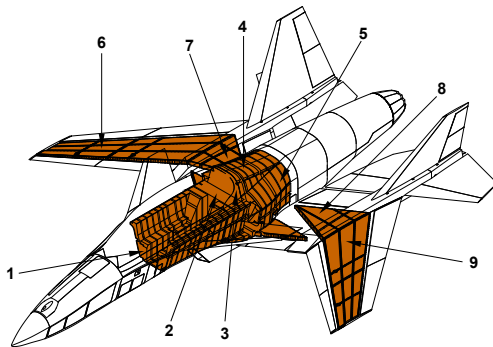

INTERNAL FUEL TANKS		USABLE FUEL			
TANK #	TANK LOCATION	US GALLONS	JP-4 POUNDS	JP-5 POUNDS	JP-8 POUNDS
1	Fuselage: 271101-T	206	1,338	1,400	1,379
2	Fuselage: 271201-T	108	703	735	724
3	Fuselage: 271301-T	59	386	404	398
4	Fuselage: 271401-T	217	1,410	1,475	1,454
5	Fuselage: 271501-T	115	749	783	772
6	Wing: 6902-R	39	251	262	258
7	Wing: 6906 & 6908-R	56	367	384	379
8	Wing: 6902-L	39	251	262	258
9	Wing: 6906 & 6908-L	56	367	384	379
<b>TOTAL INTERNAL FUEL</b>		<b>896</b>	<b>5,821</b>	<b>6,090</b>	<b>6,000</b>

EXPENDABLE/EXTERNAL TANKS		USABLE FUEL			
TANK #	TANK LOCATION	US GALLONS	JP-4 POUNDS	JP-5 POUNDS	JP-8 POUNDS
10	Right External: 401315	150	975	1,020	1,005
11	Right External: 401315	150	975	1,020	1,005
12	Left External: 401315	150	975	1,020	1,005
13	Left External: 401315	150	975	1,020	1,005
<b>TOTAL EXPENDABLE/EXTERNAL</b>		<b>600</b>	<b>3,900</b>	<b>4,080</b>	<b>4,020</b>

<b>MAXIMUM AIRCRAFT FUEL: ALL TANKS</b>	<b>1,496</b>	<b>9,721</b>	<b>10,170</b>	<b>10,020</b>
---	--------------	--------------	---------------	---------------

**NOTES:**  
 1) Fuel weights are based on JP-4 at 6.5 lbs/gal, JP-5 at 6.8 lbs/gal and JP-8 at 6.7 lbs/gal and an atmospheric temperature of 59°F.  
 2) Fuel quantities, in pounds, are rounded to the nearest pound. The actual gallons times 6.5, 6.7 or 6.8 will not necessarily agree with the pounds column.